

Accessories for MCCB **Ex9M**



- Accessories for Ex9M line devices
- Auxiliary contacts synchronous with main contacts
- Signal contacts active on electrical tripping of the circuit breaker (tripping signal contacts)
- Shunt trip and undervoltage releases
- Remote operators
- Rotary handles
- Connection terminals and covers
- Mounting depth spacers and adaptors

Accessories suitable for Moulded Case Circuit Breakers Ex9M. It is possible to supplement or modify functions of a basic circuit breaker by installing of suitable accessories.

Circuit breakers can be equipped with auxiliary contacts AX21M (up to 2 units even for M1 frame size) and one unit of signal contact AL21M. AX21M and AL21M are mounted into different positions, a use of one type of the contact does not limit a number of the second type. AX21M and AL21M can be used regardless the frame size of the circuit breaker.

One unit of undervoltage release UVT2*i* or one unit of shunt trip release SHT2*i* can be installed in the breaker. Different versions for different frame sizes allow to optimise power consumption of these units.

The circuit breakers can also be equipped with different accessories for operation of the toggle. There are available direct rotary handle, rotary handle with extended shaft e.g. for door coupling and a motor operator.

Mounting of the device onto plate can be done directly with the screws which are included in the scope of delivery. Or in case of M1 and M2 devices there is possibility to use adaptors DRA for mounting onto DIN-rail 35 mm. If it is requested to place devices of different frame size side by side, it is possible to use for compensation of differences in height mounting depth spacers WG which assure the same position of front panel towards front plate.

For connection of conductors there are available various types of box and tunnel terminals MC.

Accessories for MCCB Ex9M

Auxiliary and signal contact units

- Contact units for auxiliary and signal contact functions are suitable for all frame sizes
- Auxiliary contacts synchronous with main contacts of the circuit breaker
- Signal contacts active on electrical tripping of the circuit breaker (tripping signal contacts)
- It is possible to use 1 unit AL21 plus up to four units of AX21 in one MCCBs (depends on frame size)



Function	Frame size	Contacts	Article No.	Type	Packing
Auxiliary	all	1 CO	112071	AX21M	1/24
Signal	all	1 CO	112072	AL21M	1/24

Shunt trip releases

- It is possible to use one unit of shunt trip release SHT2*i* or one unit of undervoltage release UVT2*i*



Frame size	Operating Voltage	Article No.	Type	Packing
M1	110V AC	101398	SHT21 AC110V	1/24
M1	220-240V AC	101399	SHT21 AC220-240V	1/24
M1	380-415V AC	101400	SHT21 AC380-415V	1/24
M1	24V DC	101401	SHT21 DC24V	1/24
M1	220V DC	101405	SHT21 DC220V	1/24
M2, M3	110V AC	101417	SHT22 AC110V	1/24
M2, M3	220-240V AC	101418	SHT22 AC220-240V	1/24
M2, M3	380-415V AC	101419	SHT22 AC380-415V	1/24
M2, M3	24V DC	101420	SHT22 DC24V	1/24
M2, M3	220V DC	101424	SHT22 DC220V	1/24
M4, M5	110V AC	103723	SHT24 AC110V	1/12
M4, M5	220-240V AC	103724	SHT24 AC220-240V	1/12
M4, M5	380-415V AC	103725	SHT24 AC380-415V	1/12
M4, M5	24V DC	103729	SHT24 DC24V	1/12
M6	110V AC	110465	SHT26 AC110V	1/3
M6	220 - 240V AC	110466	SHT26 AC220-240V	1/3
M6	380 - 415V AC	110467	SHT26 AC380-415V	1/3
M6	48V AC	110464	SHT26 AC48V	1/3
M6	110V DC	110462	SHT26 DC110V	1/3
M6	220V DC	110463	SHT26 DC220V	1/3
M6	24V DC	110460	SHT26 DC24V	1/3
M6	48V DC	110461	SHT26 DC48V	1/3

Accessories for MCCB Ex9M

Undervoltage releases

■ It is possible to use one unit of undervoltage release UVT2i or one unit of shunt trip release SHT2i



Aux. cont.	Frame size	Operating Voltage	Article No.	Type	Packing
-	M1	110V AC	108814	UVT21 AC110V	1/24
-	M1	220-240V AC	101406	UVT21 220-240V AC	1/24
-	M1	380-415V AC	101407	UVT21 380-415V AC	1/24
-	M1	24V DC	110705	UVT21 24V DC	1/24
-	M1	110-120V DC	108817	UVT21 DC110-120V	1/24
-	M1	220V DC	108818	UVT21 DC220V	1/24
-	M2, M3	110V AC	108820	UVT22 AC110V	1/24
-	M2, M3	220-240V AC	101425	UVT22 220-240V AC	1/24
-	M2, M3	380-415V AC	101426	UVT22 380-415V AC	1/24
-	M2, M3	24V DC	110706	UVT22 DC24V	1/24
-	M2, M3	110-120V DC	108823	UVT22 DC110-120V	1/24
-	M2, M3	220V DC	108824	UVT22 DC220V	1/24
-	M4, M5	110V AC	103733	UVT24 AC110V	1/12
-	M4, M5	220-240V AC	103734	UVT24 AC220-240V	1/12
-	M4, M5	380-415V AC	103735	UVT24 AC380-415V	1/12
-	M4, M5	24V DC	103738	UVT24 DC24V	1/12
-	M4, M5	110-120V DC	103736	UVT24 DC110-120V	1/12
-	M4, M5	220V DC	103737	UVT24 DC220V	1/12
-	M6	220 - 240 V AC	110468	UVT26 AC220-240V	1/3
-	M6	380 - 415 V AC	110469	UVT26 AC380-415V	1/3
-	M6	48V AC	112073	UVT 26 AC48V EU	1/3
-	M6	110V AC	112074	UVT 26 AC110V EU	1/3
-	M6	24V DC	112075	UVT 26 DC24V EU	1/3
-	M6	110-120V DC	112077	UVT 26 DC110-120V EU	1/3
-	M6	220V DC	112078	UVT 26 DC220V EU	1/3

Accessories for MCCB Ex9M

Phase barriers

- Phase barriers to avoid short circuit due to ionised gas during tripping off of the breaker when unisolated busbars are used for its connection
- In the scope of delivery of MCCBs, separately orderable as a spare part
- Set consists of appropriate number of barriers suitable for both sides MCCB



Frame size	Poles	Article No.	Type	Packing
M1	3	101441	PB21 3P	1 set
M2	3	101444	PB22 3P	1 set
M3	3	101491	PB23 3P	1 set
M4, M5	3	103751	PB24 3P	1 set
M1	4	104852	PB21 4P	1 set
M2	4	104853	PB22 4P	1 set
M3	4	104854	PB23 4P	1 set
M4, M5	4	104856	PB24 4P	1 set

Remote operators

- Motor drives for electrical and remote control of MCCBs
- Available for M1-M5



Frame size	Operating Voltage	Article No.	Type	Packing
M1	380-415 V AC	112079	MOD 21 AC380-415V	1/8
M1	220-240 V AC / 220 V DC	101411	MOD 21 AC220-240V/DC220V	1/8
M1	110 V AC / 110-120 V DC	101412	MOD 21 AC110/DC110-120V	1/8
M1	24 V DC	101415	MOD 21 DC24V	1/8
M2	380-415 V AC	112080	MOD 22 AC380-415V	1/8
M2	220-240 V AC / 220 V DC	101430	MOD 22 AC220-240V/DC220V	1/8
M2	110 V AC / 110-120 V DC	101431	MOD 22 AC110/DC110-120V	1/8
M2	24 V DC	101434	MOD 22 DC24V	1/8
M3	380-415 V AC	112081	MOD 23 AC380-415V	1/4
M3	220-240 V AC / 220 V DC	101484	MOD 23 AC220-240V/DC220V	1/4
M3	110 V AC / 110-120 V DC	101485	MOD 23 AC110/DC110-120V	1/4
M3	24 V DC	101488	MOD 23 DC24V	1/4
M4, M5	380-415 V AC	112082	MOD 24 AC380-415V	1/2
M4, M5	220-240 V AC / 220 V DC	112873	MOD 24 AC220-240V/DC220V	1/2
M4, M5	110 V AC / 110-120 V DC	112874	MOD 24 AC110/DC110-120V	1/2
M4, M5	24 V DC	103747	MOD 24 DC24V	1/2

Key lock devices

- Scope of delivery: mechanism block
- Can be locked in OFF position with up to three padlocks (not in a scope of delivery)
- Compatible with padlocks with diameters of 5 up to 8mm



Frame size	Function	Article No.	Type	Packing
M1	Toggle position lock	108852	KLK 21	1/50
M2	Toggle position lock	108853	KLK 22	1/50
M3	Toggle position lock	108854	KLK 23	1/50

Accessories for MCCB Ex9M

Mechanical interlocks

- Scope of delivery: mechanical interlock
- Installation in front toggles of the MCCBs, is not possible to install with other front mounted accessories i.e. ERH, MOD, RHD
- Suitable for mechanical interconnection of two pieces of MCCBs from the same frame size



Frame size	Function	Article No.	Type	Packing
M1	Avoids simultaneous connection	108855	MIT 21	1/50
M2	Avoids simultaneous connection	108856	MIT 22	1/50
M3	Avoids simultaneous connection	108857	MIT 23	1/50
M4, M5	Avoids simultaneous connection	108858	MIT 24	1/50

Direct rotary handles

- Rotary handle for direct mounting onto breaker
- Scope of delivery: mechanism block, rotary handle
- Indication of connected breaker status ON-OFF-TRIP
- Degree of protection IP40, IK07
- Can be locked in ON and OFF position with up to three padlocks (not in a scope of delivery)



Frame size	Colour	Article No.	Type	Packing
M1	Grey	101410	RHD 21	1/36
M2	Grey	101429	RHD 22	1/18
M3	Grey	101483	RHD 23	1/9
M4, M5	Grey	103742	RHD 24	1/6

Extended rotary handles

- Rotary handle with extension shaft (extension shaft can be shortened)
- Possibility of longer extension shaft 500 mm (only the shaft as separated item)
- Scope of delivery: mechanism block, extension shaft, rotary handle
- Indication of connected breaker status ON-OFF-TRIP
- Degree of protection IP54, IK08
- Can be locked in ON and OFF position with up to three padlocks (not in a scope of delivery)



Frame size	Length	Colour	Article No.	Type	Packing
M1	300 mm	Grey	101409	ERH 21	1/6
M2	300 mm	Grey	101428	ERH 22	1/6
M3	300 mm	Grey	101482	ERH 23	1/6
M4, M5	300 mm	Grey	103741	ERH 24	1/4
All (only the shaft)	500 mm	-	110189	ERH2x ES 500mm	1/50

Extended handle

- For easier operation of the toggle
- Only for frame size M6 (not compatible with MOD version)



Suitable MCCB	Colour	Article No.	Type	Packing
Ex9M6/SD	Grey	110698	LHD26	1/20

Accessories for MCCB Ex9M

Connection accessories

- Connection terminals for MCCBs of all frame sizes
- Box and tunnel terminal versions
- For connecting with Al or Cu wires (box terminals only for Cu wires)
- Packed separately (for 3P connection, it is necessary to order 3pcs of terminal)
- Box terminals newly in the scope of delivery of AC devices M1, M2
- Front connection plates for frame sizes from M1 until M3
- Rear connection plates for frame sizes from M1 until M5



Box terminals

Frame size	Version	Terminals	Max. terminal capacity	Article No.	Type	Packing
M1	box	1	4-95 mm ²	103705	MC21	1
M2	box	1	10-120 mm ²	103709	MC22	1
M3	box	1	120-240 mm ²	103715	MC23	1
M3	box	1	120-240 mm ²	103717	MC23 UL	1



Tunnel terminals

Frame size	Version	Terminals	Max. terminal capacity	Article No.	Type	Packing
M1	tunnel	1	16-95 mm ²	103707	MC21 W	1
M2	tunnel	1	35-240 mm ²	103869	MC22 W	1
M2	tunnel	2	35-120 mm ²	103711	MC22 W2	1
M2	tunnel	6	10-35 mm ²	103713	MC22 W6	1
M3	tunnel	2	120-240 mm ²	103719	MC23 W2	1
M3	tunnel	2	120-240 mm ²	103871	MC23 W2 UL	1
M3	tunnel	4	35-95 mm ²	103721	MC23 W4	1
M4, M5	tunnel	2	120-240 mm ²	106314	MC24 W2	1
M6	tunnel	3	120-240 mm ²	112091	MC26 W3	1
M6	tunnel	4	120-240 mm ²	112092	MC26 W4	1



Screw terminals

Frame size	Version	Terminals	Screw size	Article No.	Type	Packing
M1	screw	1	M6	107873	MCS21	1
M2	screw	1	M8	107874	MCS22	1

Front connection plates



Frame size	Thickness (mm)	Plates per set	Busbar width (mm)	Article No.	Type	Packing
M1	4	3	15	108859	JP21 3P	1 set
M1	4	4	15	108865	JP21 4P	1 set
M2	5	3	20	108860	JP22 3P	1 set
M2	5	4	20	108866	JP22 4P	1 set
M3	8	3	30	108861	JP23 3P	1 set
M3	8	4	30	108867	JP23 4P	1 set
M6	10	3		110694	JP26 3P 800-1250	1 set
M6	20	3		110695	JP26 3P 1600	1 set
M6	10	4		110696	JP26 4P 800-1250	1 set
M6	20	4		110697	JP26 4P 1600	1 set



Rear connection plates

Frame size	Thickness (mm)	Plates per set	Busbar width (mm)	Article No.	Type	Packing
M1	3.5	6	12.5	108871	RCP21 3P	1 set
M1	3.5	8	12.5	108875	RCP21 4P	1 set
M2	6	6	18	108872	RCP22 3P	1 set
M2	6	8	18	108876	RCP22 4P	1 set
M3	8	6	30	108873	RCP23 3P	1 set
M3	8	8	30	108877	RCP23 4P	1 set
M4, M5	8	6	40	108874	RCP24 3P	1 set
M4, M5	8	8	40	108878	RCP24 4P	1 set

Accessories for MCCB Ex9M

Plug-in bases

- Suitable for circuit breakers of frame sizes from M1 until M3
- Offered with front type and back type of terminals
- In scope of delivery the tripping mechanism, phase barriers, MCCB plug-in terminals, mounting screws and the plug-in base.



Frame size	Connection type	Poles	Article No.	Type	Packing
M1 TM	Front	3	112875	PIA 21F 3P	1/4
M1 TM	Front	4	112876	PIA 21F 4P	1/4
M2 TM	Front	3	112877	PIA 22F 3P	1/2
M2 TM	Front	4	112878	PIA 22F 4P	1/2
M2 SU	Front	3	112093	PIA 22F 3P SU20	1/2
M2 SU	Front	4	112094	PIA 22F 4P SU20	1/2
M3 TM	Front	3	112879	PIA 23F 3P	1/1
M3 TM	Front	4	112880	PIA 23F 4P	1/1
M3 SU	Front	3	112095	PIA 23F 3P SU20 EU	1/1
M3 SU	Front	4	112096	PIA 23F 4P SU20 EU	1/1
M1 TM	Back	3	112881	PIA 21B 3P EU	1/4
M1 TM	Back	4	112882	PIA 21B 4P EU	1/4
M2 TM	Back	3	112883	PIA 22B 3P EU	1/2
M2 TM	Back	4	112884	PIA 22B 4P EU	1/2
M2 SU	Back	3	112097	PIA 22B 3P SU20 EU	1/2
M2 SU	Back	4	112098	PIA 22B 4P SU20 EU	1/2
M3 TM	Back	3	112885	PIA 23B 3P EU	1/1
M3 TM	Back	4	112886	PIA 23B 4P EU	1/1
M3 SU	Back	3	112099	PIA 23B 3P SU20 EU	1/1
M3 SU	Back	4	112100	PIA 23B 4P SU20 EU	1/1

Draw-out bases

- Suitable for circuit breakers of frame sizes from M3 to M5
- Offered with front type and back type of terminals
- In scope of delivery the tripping mechanism, base position indicators, phase barriers, MCCB plug-in terminals, auxiliary terminals for the cassette, mounting screws, phase barriers and the draw-out base.



Frame size	Connection type	Poles	Article No.	Type	Packing
M3 TM	Front	3	108887	DOB 23F 3P CO (400A)	1
M3 TM	Front	4	108899	DOB 23F 4P CO (400A)	1
M3 TM	Front	3	108889	DOB 23F 3P CO (630A)	1
M3 TM	Front	4	108901	DOB 23F 4P CO (630A)	1
M3 SU	Front	3	112101	DOB 23F 3P CO SU20(400A)	1
M3 SU	Front	4	112102	DOB 23F 4P CO SU20(400A)	1
M3 SU	Front	3	112105	DOB 23F 3P CO SU20(630A)	1
M3 SU	Front	4	112106	DOB 23F 4P CO SU20(630A)	1
M4, M5 TM / SU	Front	3	108891	DOB 24F 3P CO	1
M4, M5 TM / SU	Front	4	108903	DOB 24F 4P CO	1
M3 TM	Back	3	108893	DOB 23B 3P CO (400A)	1
M3 TM	Back	4	108905	DOB 23B 4P CO (400A)	1
M3 TM	Back	3	108895	DOB 23B 3P CO (630A)	1
M3 TM	Back	4	108907	DOB 23B 4P CO (630A)	1
M3 SU	Back	3	112103	DOB 23B 3P CO SU20(400A)	1
M3 SU	Back	4	112104	DOB 23B 4P CO SU20(400A)	1
M3 SU	Back	3	112107	DOB 23B 3P CO SU20(630A)	1
M3 SU	Back	4	112108	DOB 23B 4P CO SU20(630A)	1
M4, M5 TM / SU	Back	3	108897	DOB 24B 3P CO	1
M4, M5 TM / SU	Back	4	108909	DOB 24B 4P CO	1

Accessories for MCCB Ex9M

Terminal covers, short

- Terminal covers to increase touch protection of terminals



Frame size	Poles	Article No.	Type	Packing
M1	3	101439	TCV21 3P	1
M2	3	101442	TCV22 3P	1
M3	3	101489	TCV23 3P	1
M4, M5	3	103748	TCV24 3P	1
M1	4	102372	TCV21 4P	1
M2	4	102374	TCV22 4P	1
M3	4	102376	TCV23 4P	1
M4, M5	4	103750	TCV24 4P	1

Terminal covers, long

- Terminal covers to increase touch protection of terminals



Frame size	Poles	Article No.	Type	Packing
M1	3	101440	TCE21 3P	1
M2	3	101443	TCE22 3P	1
M3	3	101490	TCE23 3P	1
M4, M5	3	103749	TCE24 3P	1
M1	4	102373	TCE21 4P	1
M2	4	102375	TCE22 4P	1
M3	4	102377	TCE23 4P	1
M4, M5	4	104855	TCE24 4P	1

DIN-rail adaptors

- Adaptors for mounting of MCCBs onto DIN-rail 35 mm
- Suitable for all variants of MCCBs and MCCB Switch Disconnectors of given frame size



Frame size	Poles	Article No.	Type	Packing
M1	3, 4	106319	DRA21	1
M2	3, 4	106320	DRA22	1

Mounting depth spacers

- Set of mounting depth spacers for compensation of differences in height between frame sizes
- Assures the same position of front panel towards front plate
- Two variants with height 10 and 13 mm
- For compensation of heights please use these configuration:
 - M1 -> M2 = 1x WG10
 - M1 -> M3 = 1x WG10 + 2x WG13
 - M1 -> M4, M5 = 1x WG10 + 3x WG13
 - M2 -> M3 = 2x WG13
 - M2 -> M4, M5 = 3x WG13
 - M3 -> M4, M5 = 1x WG13



Frame size	Height	Article No.	Type	Packing
M1	10 mm	106321	WG 10	1 set
M2, M3, M4, M5	13 mm	106362	WG 13	1 set

Accessories for MCCB **Ex9M**

Battery box

- Battery box for smart unit's power supply
- Applicable to SU20S moulded case circuit breaker



Frame sizes	Article No.	Type	Packing
M2-M6	115642	BAB22	1

Communication module

- Communication module for electronic type moulded case circuit breaker
- Communication protocol through Modbus



Frame size	Cable length	Current	Article No.	Type	Packing
M2-M6	3m	AC	117286	COM22 AC230V 3M	1
M2-M6	1.5m	AC	117285	COM22 AC230V 1.5M	1
M2-M6	0.5m	AC	117284	COM22 AC230V 0.5M	1
M2-M6	3m	DC	117289	COM22 DC24V 3M	1
M2-M6	1.5m	DC	117288	COM22 DC24V 1.5M	1
M2-M6	0.5m	DC	117287	COM22 DC24V 0.5M	1

Technical Data **Ex9M** Accessories

Accessories for Moulded Case Circuit Breakers Ex9M

Auxiliary and signal contact units AX21, AL21

General parameters

Contact units for auxiliary and signal contact functions are suitable for all MCCB frame sizes

Auxiliary contacts synchronous with main contacts of the circuit breaker

Signal contacts active on electrical tripping of the circuit breaker (tripping signal contacts)

Electrical parameters

	AX21	AL21
Contacts	1 changeover (CO)	1 changeover (CO)
Contact function	auxiliary	signal
Tested according to	IEC/EN 60947-1, IEC/EN 60947-5-1	
Rated op. voltage U	240/415 V AC, 110/220 V DC	
Rated frequency	50/60 Hz	
Rated op. current I _e AC	4 A (240 V), 2 A (415 V)	
Rated op. current I _e DC	0.25 A (110 V), 0.25 A (220 V)	
Rated thermal current I _{th}	5 A	
Rated op. current I _e , ut. cat. AC-15	4 A (240 V), 2 A (415 V)	
Rated op. current I _e , ut. cat. DC-13	0.25 A (110 V), 0.25 A (220 V)	
Rated insulation voltage U _i	500 V	

Mechanical parameters

	AX21	AL21
Suitable for	M1, M2, M3, M4, M5	M1, M2, M3, M4, M5
Connection	screw terminals	

Wiring diagrams

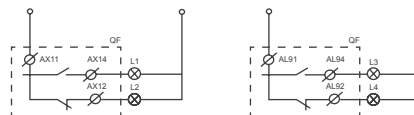

AX21

AL21

Technical Data **Ex9M** Accessories

Accessories for Moulded Case Circuit Breakers Ex9M

Shunt trip releases SHT2*i*

General parameters

It is possible to use one unit of shunt trip release SHT2*i* or one unit of undervoltage release UVT2*i*

Can be used for remote switch off

SHT21 for MCCBs of frame size M1

SHT22 for MCCBs of frame sizes M2 and M3

SHT24 for MCCBs of frame sizes M4 and M5

SHT26 for MCCBs of frame size M6

With connection wires

Electrical parameters

	SHT21	SHT22	SHT24	SHT26
Tested according to	IEC/EN 60947-1, IEC/EN 60947-5-1			
Rated operating voltage U (according to type)	110 V AC 220 — 240 V AC 380 — 415 V AC 24 V DC 220 V DC	110 V AC 220 — 240 V AC 380 — 415 V AC 24 V DC 220 V DC	110 V AC 220 — 240 V AC 380 — 415 V AC 110 — 120 V DC 220 V DC 24 V DC	110 V AC 220 — 240 V AC 380 — 415 V AC 110 — 120 V DC 220 V DC 24 V DC
Rated frequency	50/60 Hz DC			
Rated insulation voltage U	500 V			
Tripping time	< 20 ms	< 20 ms	< 30 ms	<100 ms

Mechanical parameters

	SHT21	SHT22	SHT24	SHT26
Suitable for	M1	M2, M3	M4, M5	M6
Connection	equipped with connection wires			

Wiring diagrams

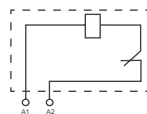

SHT2*i*

Connection diagram for long control signals

In case external control circuit cannot assure not-exceeding of max. impuls duration, AX contact of NO configuration can be used for limiting (direct connection with SHT 230 or 400 V AC, signal to advanced control system in case of use of SHT for DC control voltages due to maximum allowed current of AX).

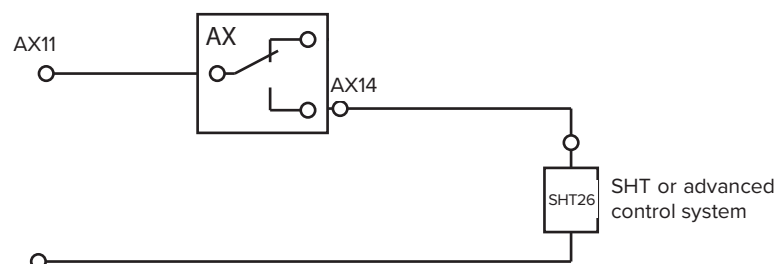

Technical Data **Ex9M** Accessories

Accessories for Moulded Case Circuit Breakers Ex9M

Undervoltage releases UVT2*i*

General parameters

It is possible to use one unit of shunt trip release SHT2*i* or one unit of undervoltage release UVT2*i*

To switch connected breaker off in case of voltage drop

UVT21 for MCCBs of frame size M1

UVT22 for MCCBs of frame size M2 and M3

UVT24 for MCCBs of frame size M4 and M5

UVT26 for MCCBs of frame size M6

With connection wires

Electrical parameters

	UVT21	UVT22	UVT24	UVT26
Tested according to	IEC/EN 60947-1, IEC/EN 60947-5-1			
Rated operating voltage U_n	220 — 240 V AC 380 — 415 V AC	220 — 240 V AC 380 — 415 V AC	110 V AC 220 — 240 V AC 380 — 415 V AC 110 — 120 V DC 220 V DC 24 V DC	110 V AC 220 — 240 V AC 380 — 415 V AC 110 — 120 V DC 220 V DC 24 V DC 48 V DC
Rated frequency f	50/60 Hz DC			
Rated insulation voltage U_i	500 V			
Tripping time	< 20 ms	< 20 ms	< 20 ms	< 100
Making threshold	85 % U_n	85 % U_n	85 % U_n	85 % U_n
Tripping threshold	35 % U_n	35 % U_n	35 % U_n	35 % U_n

Mechanical parameters

	UVT21	UVT22	UVT24	UVT26
Suitable for	M1	M2, M3	M4, M5	M6
Connection	equipped with connection wires			

Wiring diagrams

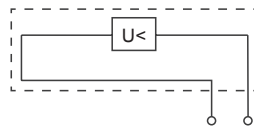

UVT2*i*

Technical Data **Ex9M** Accessories

Accessories for Moulded Case Circuit Breakers Ex9M

Remote motor operators MOD2i

General parameters

Motor drives for electrical and remote control of MCCBs

Electrical parameters

	MOD21	MOD22	MOD23	MOD24
Tested according to	IEC/EN 60947-1, IEC/EN 60947-5-1			
Rated operating voltage U_s (according to type)	230 V AC 110 V AC 220 V DC 110 V DC 24 V DC			
Rated frequency	50/60 Hz DC			
Power consumption	150 VA	150 VA	300 VA	300 VA
Total time to switch ON	500 ms	500 ms	1000 ms	1000 ms
Total time to switch OFF	500 ms	500 ms	1000 ms	1000 ms
Min. pulse duration for ON	300 ms	300 ms	300 ms	300 ms
Min. pulse duration for OFF	300 ms	300 ms	300 ms	300 ms
Max. pulse duration	limited by internal contact switch			

Mechanical parameters

	MOD21	MOD22	MOD23	MOD24
Suitable for	M1	M2	M3	M4, M5
Terminals	lift			
Terminal capacity	0.2 – 1.5 mm ²			
Mechanical service life	10 000 operation cycles		8 000 operation cycles	
Maximum frequency of switch. cycles	120 operating cycles per hour			

Wiring diagram

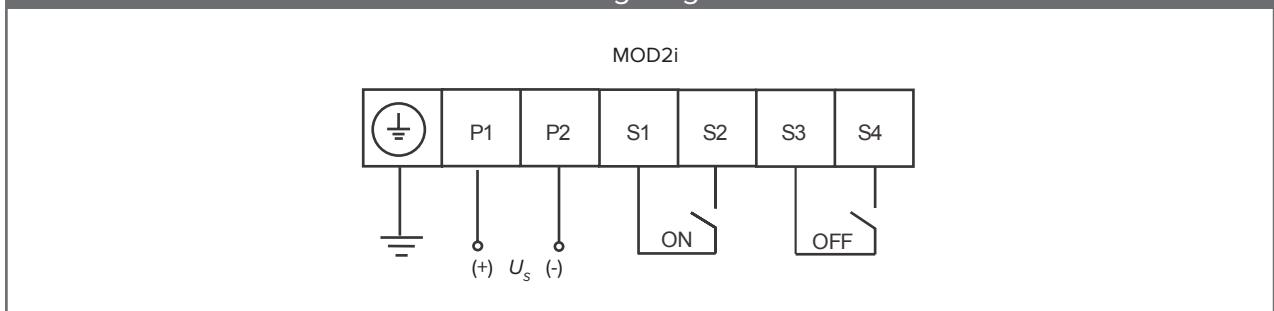

Technical Data **Ex9M** Accessories

Accessories for Moulded Case Circuit Breakers Ex9M

Remote motor operators MOD2i

Dimensions

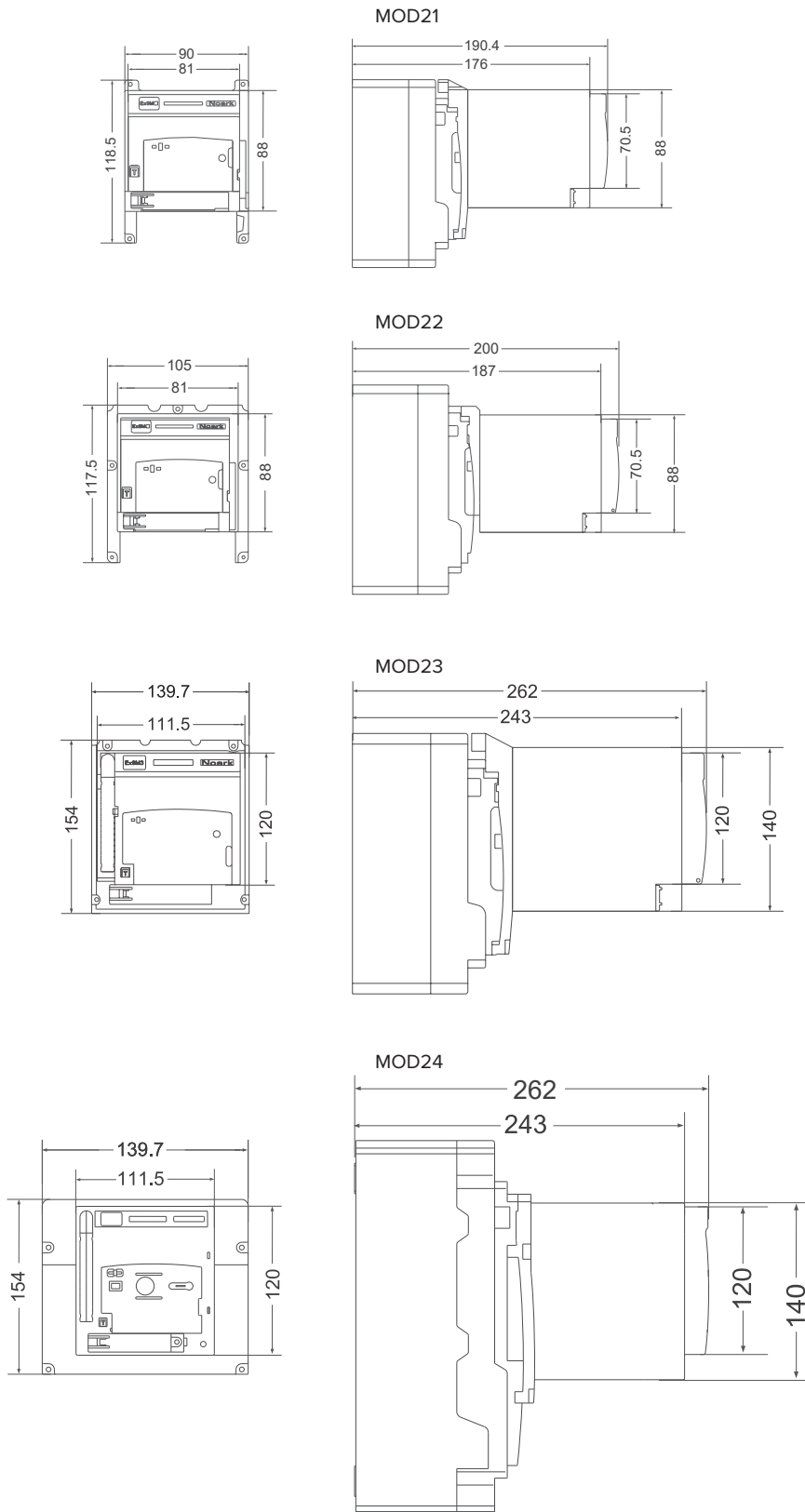

Technical Data **Ex9M** Accessories

Accessories for Moulded Case Circuit Breakers Ex9M

Mechanical interlocks MIT2*i*

General parameters

Avoid simultaneous connection of two interlocked MCCBs

Suitable for two circuit breakers of the same frame size

To be installed in the front of the circuit breakers, incompatible with other accessories installed in the front (RHD, ERH, MOD)

Mechanical parameters

	MIT 21	MIT 22	MIT 23	MIT 24
Suitable for: Ex9M TM Ex9M SU Ex9M SD	M1	M2	M3	M4 / M5
Mounting	front cover			
Locking	Padlock, 5 up to 8mm diameter			

Diagram

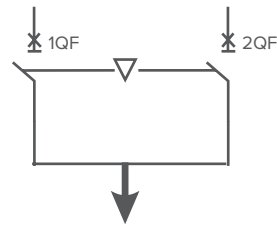
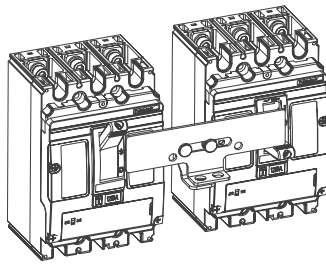

Dimensions

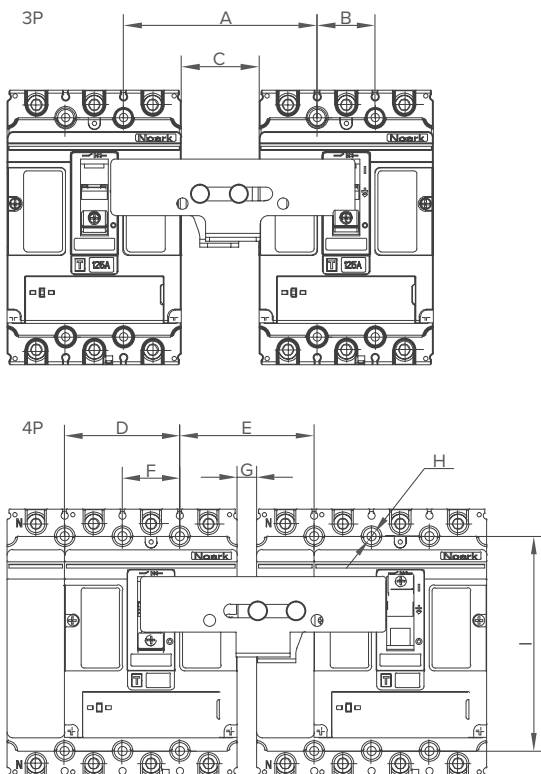

(mm)	MIT 21	MIT 22	MIT 23	MIT 24
A	100	115	143.5	205
B	30	35	45	65
C	40	45	48.5	75
D	60	70	90	130
E	70	80	98.5	140
F	30	35	45	65
G	10	10	3.5	10
H	Ø4.5	Ø5.5	Ø5.5	Ø6.5
I	112	125	201	235

Technical Data **Ex9M** Accessories

Accessories for Moulded Case Circuit Breakers Ex9M

Direct rotary handles RHD2i

General parameters

Rotary handle for direct mounting onto breaker

Scope of delivery: mechanism block, rotary handle

Can be locked in ON and OFF position with up to three padlocks (not in the scope of delivery)

Electrical parameters

	RHD21	RHD22	RHD23	RHD24
Tested according to	IEC/EN 60947-3			
Degree of protection	IP40			

Mechanical parameters

	RHD21	RHD22	RHD23	RHD24
Suitable for	M1	M2	M3	M4, M5
Mechanical shock resistance	IK07			
Indication	connected breaker status ON-OFF-TRIP			
Mounting	directly onto breaker			
Toggle colour	grey			

Dimensions

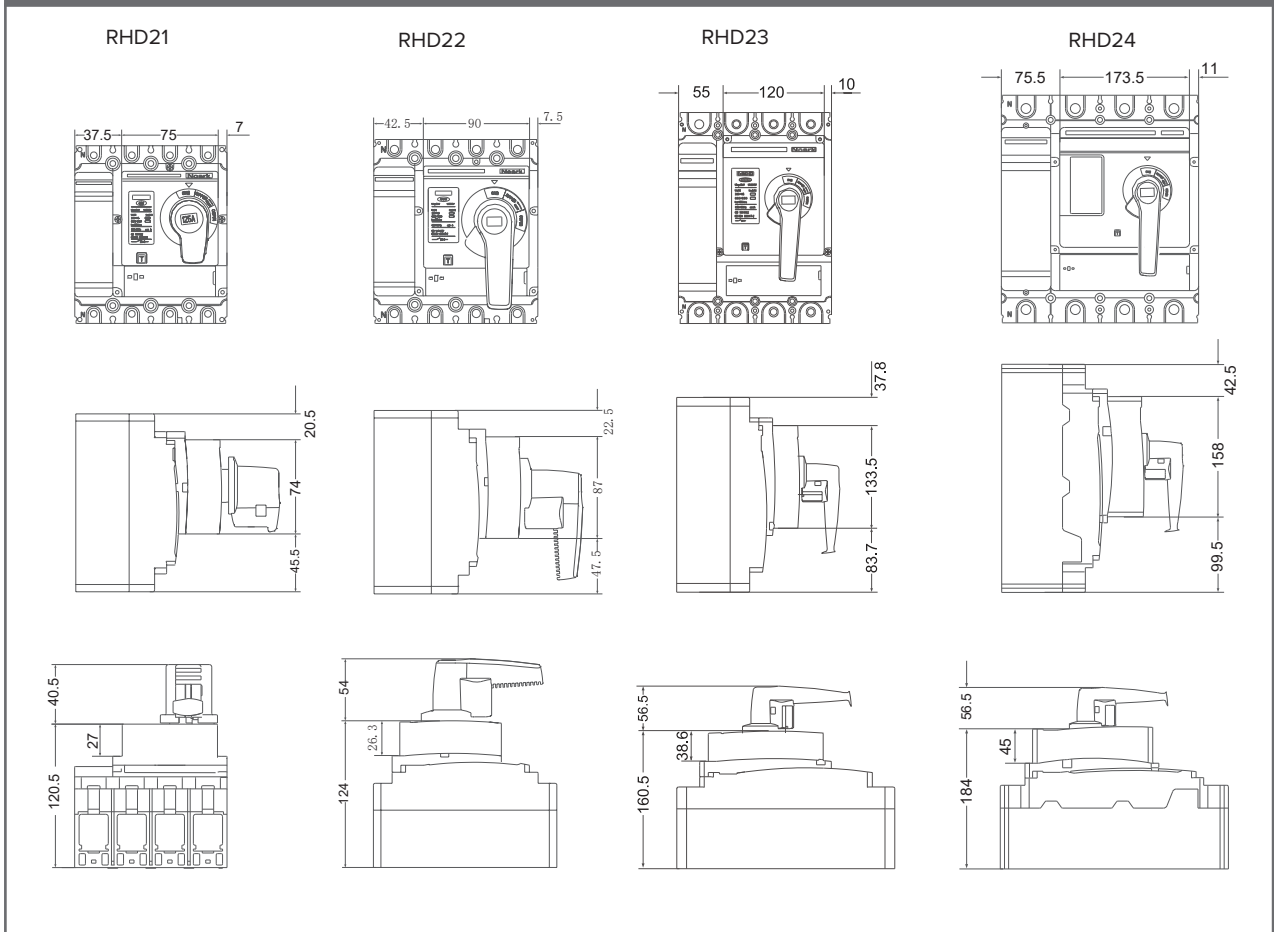

Technical Data **Ex9M** Accessories

Accessories for Moulded Case Circuit Breakers Ex9M

Extended rotary handles ERH2i

General parameters

Rotary handle with extension shaft
Scope of delivery: mechanism block, extension shaft, rotary handle
Can be locked in ON and OFF position with up to three padlocks (not in the scope of delivery)
Extension shaft can be shortened
Possibility of longer extension shaft 500 mm (only the shaft as separated item)

Electrical parameters

	ERH21	ERH22	ERH23	ERH24	ERH26
Tested according to	IEC/EN 60947-3				
Degree of protection	IP54				IP30

Mechanical parameters

	ERH21	ERH22	ERH23	ERH24	ERH26
Suitable for	M1	M2	M3	M4, M5	M6
Length of the extension shaft	300 mm	300 mm	300 mm	300 mm	150 mm
Mechanical shock resistance	IK08				
Indication	connected breaker status ON-OFF-TRIP				
Mounting	directly onto breaker				
Toggle colour	grey				black

Dimensions

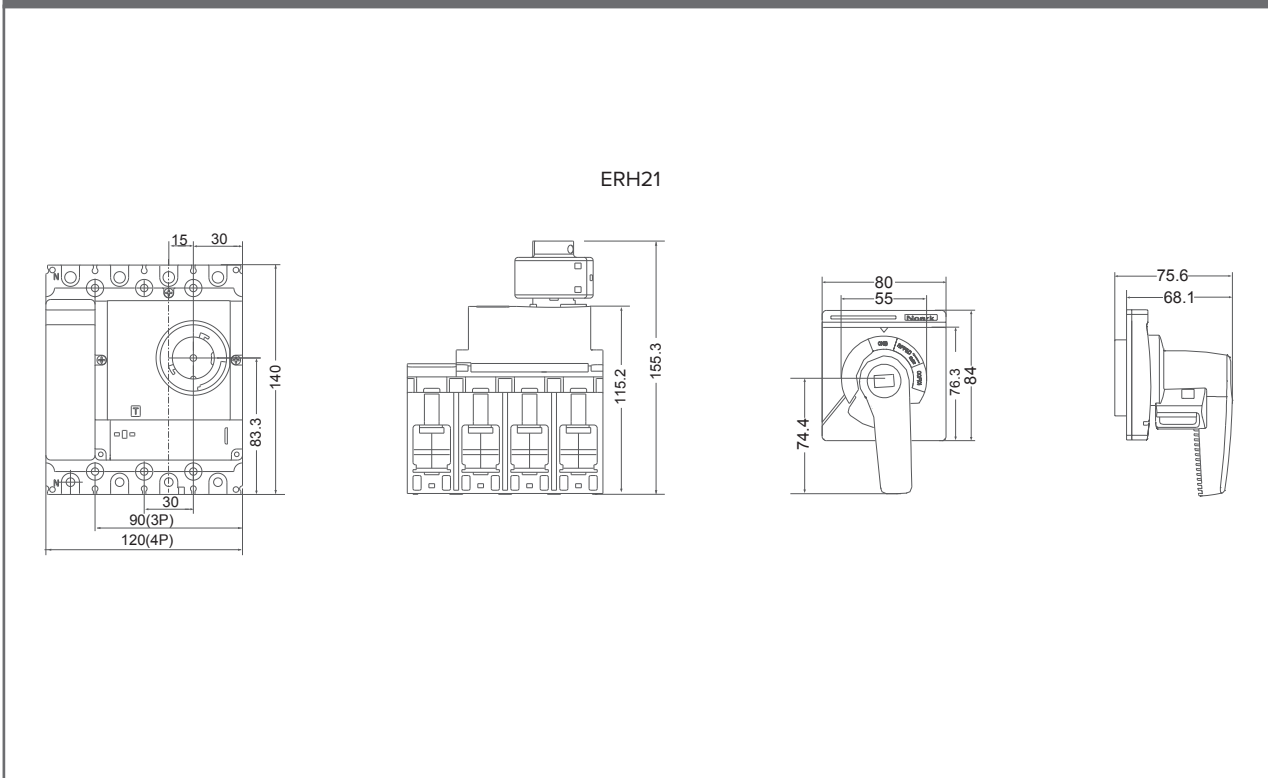

Technical Data **Ex9M** Accessories

Accessories for Moulded Case Circuit Breakers Ex9M

Extended rotary handles ERH2i

Dimensions

ERH22

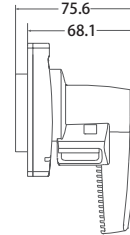
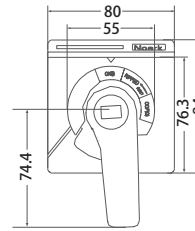
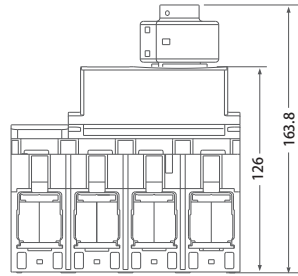
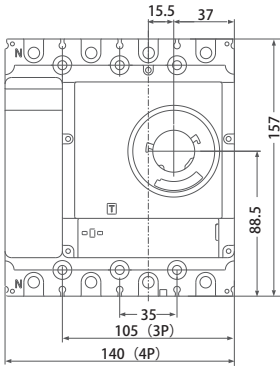

ERH23

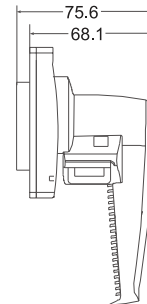
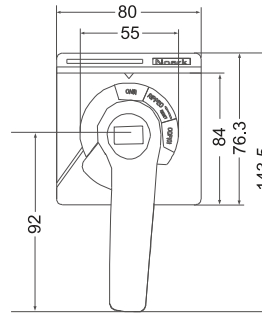
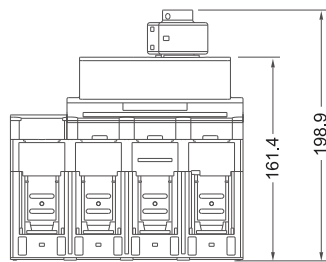
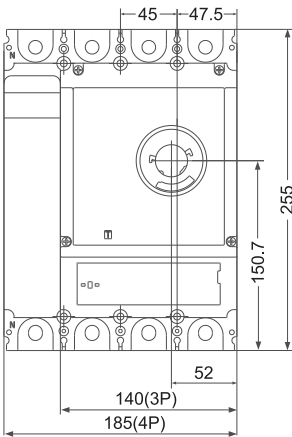

ERH24

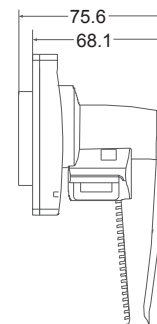
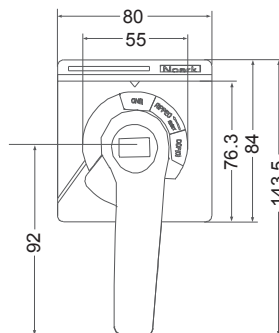
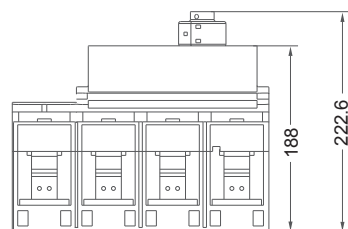
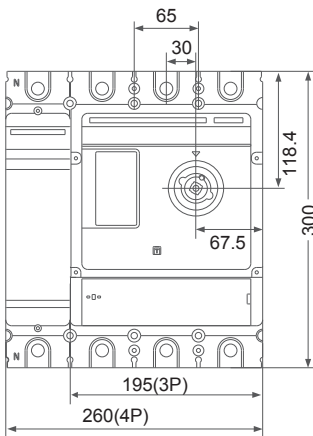

Technical Data **Ex9M** Accessories

Accessories for Moulded Case Circuit Breakers Ex9M

Extended handle LHD26

General parameters

Extended handle for easier operation of the device

Scope of delivery: mechanism locker, extended handle

Mechanical parameters

	LHD26
Suitable for	Ex9M6
Length of the extended toggle	172 mm min
Indication	connected breaker status ON-OFF-TRIP
Mounting	directly onto breaker
Toggle colour	grey

Dimensions

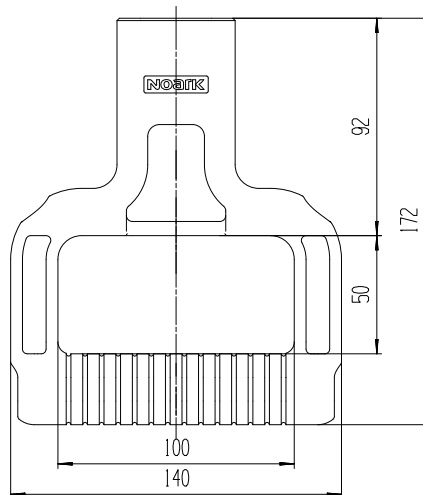

Technical Data **Ex9M** Accessories

Accessories for Moulded Case Circuit Breakers Ex9M

Connection terminals MC2i

General parameters

Box and tunnel connection terminals for Ex9M MCCBs and MCCB based switch disconnectors

Versions suitable for all frame sizes

Screws in the scope of delivery

Mechanical parameters - box terminals

	MC21	MC22	MC23	MC23 UL
Suitable for	M1	M2	M3	M3
Terminal type	box			
Terminal capacity	4 – 95 mm ²	10 – 120 mm ²	120 – 240 mm ²	120 – 240 mm ²
Fastening torque of terminals	8 Nm	10 Nm	35 Nm	35 Nm

Drawings - box terminals



MC21(22)



MC23

Mechanical parameters - tunnel terminals

	MC21 W	MC22 W	MC22 W2	MC22 W6	MC23 W2	MC23 W4	MC24 W2	MC26 W3	MC26 W4
Suitable for	M1	M2	M2	M2	M3	M3	M4, M5	M6	M6
Terminal type	tunnel								
Terminal capacity	1x 16 - 95 mm ²	1x 35 - 240 mm ²	2x 35 - 120 mm ²	6x 10 - 35 mm ²	2x 120 - 240 mm ²	4x 35 - 95 mm ²	2x 240 mm ²	3x 95 - 300 mm ²	4x 95 - 240 mm ²
Fastening torque of terminals (to MCCB)	10 - 15 Nm	15 Nm	15 Nm	15 Nm	35 Nm	35 Nm	35 Nm	35 Nm	35 Nm
Fastening torque of terminals (wires)	10 Nm	30 Nm	30 Nm	10 Nm	35 Nm	15 Nm	35 Nm	35 Nm	35 Nm

Drawings - tunnel terminals

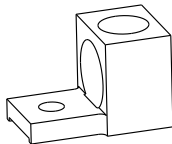

MC22 W

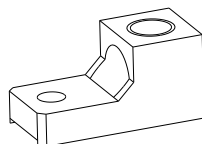

MC22 W2

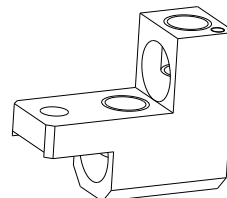

MC24 W2

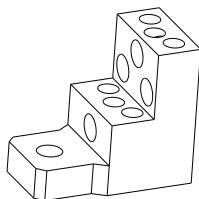

MC22 W6

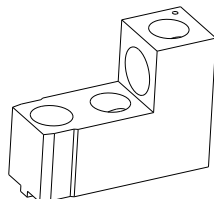

MC23 W2

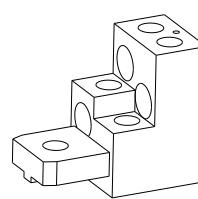

MC23 W4

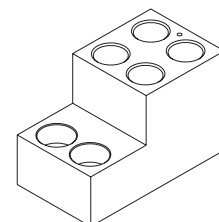

MC26 W4

Technical Data **Ex9M** Accessories

Accessories for Moulded Case Circuit Breakers Ex9M

Front connection plates JP

General parameters

Front connection plates JP for frame sizes M1, M2, M3 and M6

Mechanical parameters - Front connection plates JP

	JP21	JP22	JP23
Suitable for	M1	M2	M3
Terminal pitch	30 mm	35 mm	53 mm
Busbar / cable lug width	15 mm	20mm	30 mm
Terminal screw size	M6	M8	M10
Fastening torque of terminals	6 Nm	11 Nm	25 Nm

Dimensions

JP21

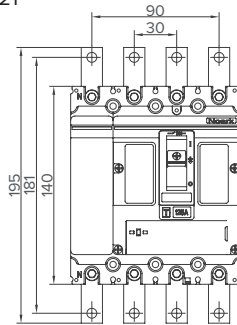

8

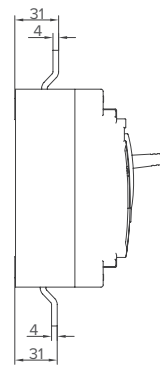

JP22

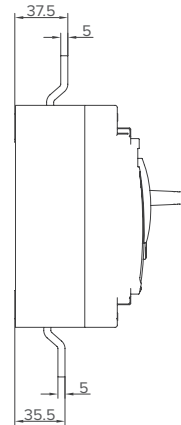
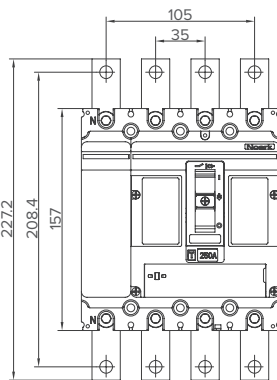

JP23

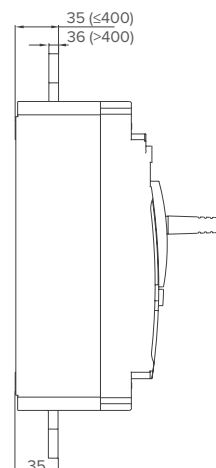
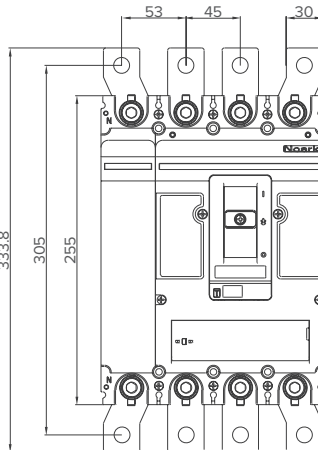
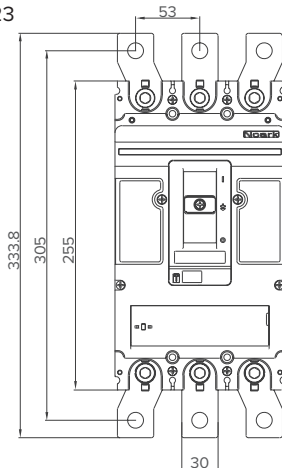

Technical Data **Ex9M** Accessories

Accessories for Moulded Case Circuit Breakers Ex9M

Rear connection plates RCP

General parameters

Front connection plates JP for frame sizes from M1 up to M3

Rear connection plates RCP for frame sizes from M1 up to M5

Mechanical parameters - rear connection plates RCP

	RCP21	RCP22	RCP23	RCP24
Suitable for	M1	M2	M3	M4 / M5
Terminal pitch	30 mm	35 mm	53 mm	65 mm
Busbar / cable lug width	12.5 mm	20mm	30 mm	40 mm
Terminal screw size	M6	M8	M10	M12
Fastening torque of terminals	6 Nm	11 Nm	25 Nm	25 — 30 Nm

Dimensions

RCP21

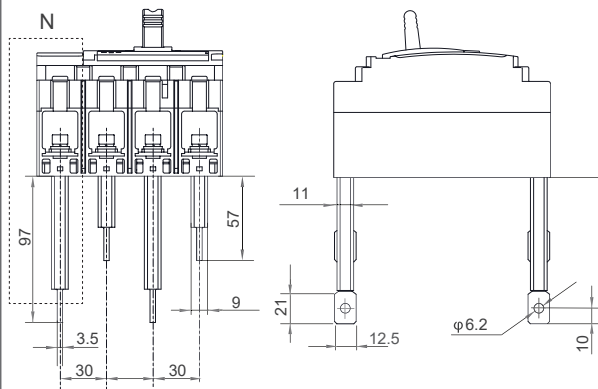

RCP22

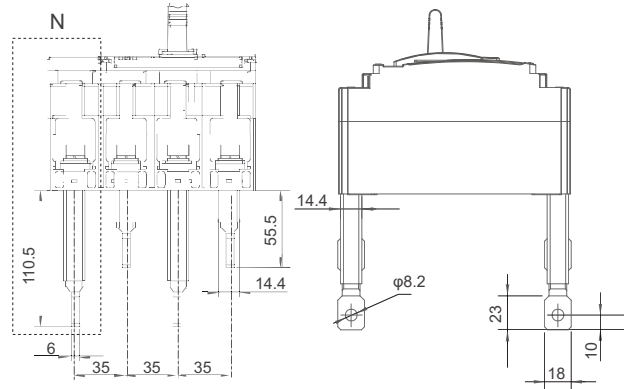

RCP23

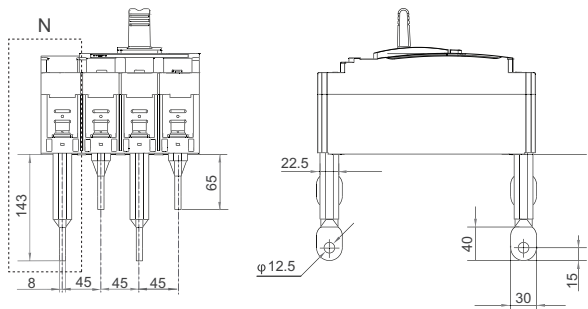

RCP24

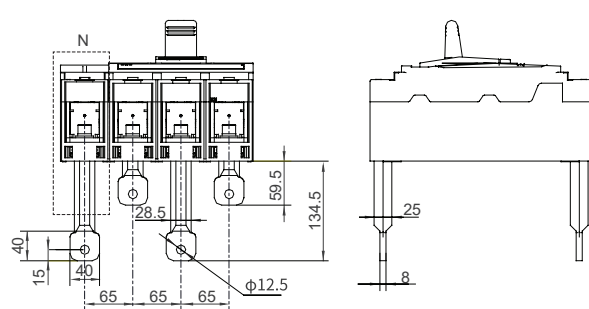

Technical Data **Ex9M** Accessories

Accessories for Moulded Case Circuit Breakers Ex9M

Plug-in base PIA2i

General parameters

Suitable for commercial and industrial applications
For fast service and maintenance of the installation
Suitable for circuit breakers of frame sizes from M1 until M3
Thermomagnetic and electronic variants have different models available
Premounted with automatic safety trip mechanism to avoid damages while unplugging the circuit breaker.
Offered with front type and back type of terminals.
In scope of delivery the tripping mechanism, phase barriers, MCCB plug-in terminals, mounting screws, phase barriers and the plug-in base.

Derating coefficient of Tripping Characteristics on accessories combination

Nominal current	I_n (T) [A]				
	Ex9M1 TM	Ex9M2 TM	Ex9M3 TM	Ex9M2 SU20	Ex9M3 SU20
16 – 50 A	1	—	—	1	—
63 A	1	—	—	1	—
80 A	1	—	—	—	—
100 A	1	—	—	1	—
125 A	0.95	1	—	—	—
160 A	0.95	1	—	1	—
180 A	—	1	—	—	—
200 A	—	0.95	—	—	—
225 A	—	0.95	—	—	—
250 A	—	0.95	1	0.95	1
315 A	—	—	1	—	—
350 A	—	—	1	—	—
400 A	—	—	1	—	1
500 A	—	—	0.95	—	—
630 A	—	—	—	—	0.9 (≤570A)

Mechanical parameters

	PIA21	PIA22 / PIA22 SU20	PIA23 / PIA23 SU20
Device width 3P / 4P	90 mm / 120 mm	105 mm / 140 mm	140 mm / 185 mm
Device height front / back connection	252 mm / 186 mm	267 mm / 201 mm	359 mm / 326 mm
Device depth with MCCB mounted front connection	176 mm	193 mm	260 mm
Device depth with MCCB mounted back connection	230 mm	247 mm	325 mm
Mounting	onto panel / DIN rail 35mm		
Degree of protection	IP40, IP20 terminals		
Terminals	M8 screws	M8 screws	M10 screws
Busbar width	≤ 15 mm	≤ 18 mm	≤ 28 mm
Cable lug width	≤ 15 mm	≤ 18 mm	≤ 28 mm
Fastening torque of terminals	9 Nm	9 Nm	15 Nm
Ambient temperature	-40 — +70 °C		
Relative humidity	≤ 50 % at 40 °C, ≤ 90 % monthly average		
Weight 3P / 4P (front connection)	1 / 1.35 kg	1.64 / 2.23 kg	5.95 / 7.86 kg
Mounting position	vertical, can be rotated by 90° in each axis		

Technical Data **Ex9M** Accessories

Accessories for Moulded Case Circuit Breakers Ex9M

Plug-in base PIA2i

Dimensions

PIA 21

mm

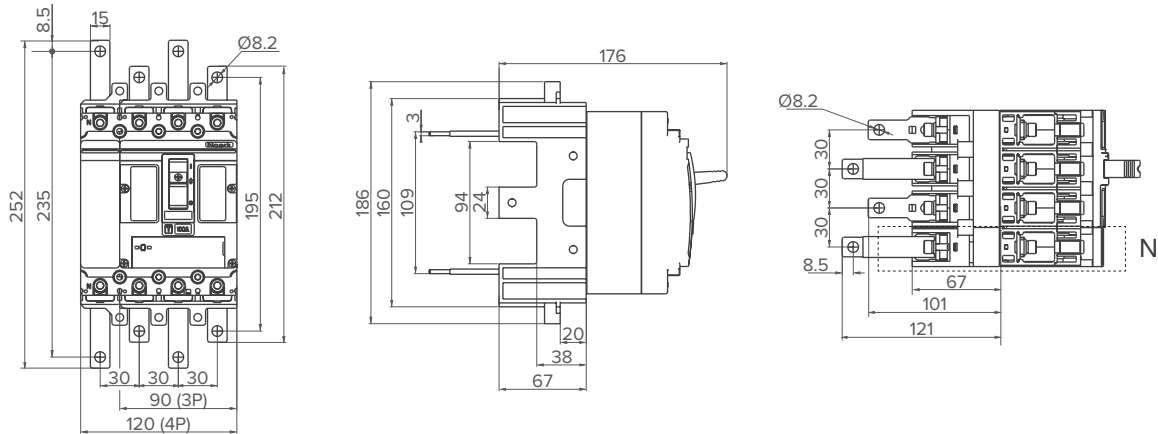

PIA 22

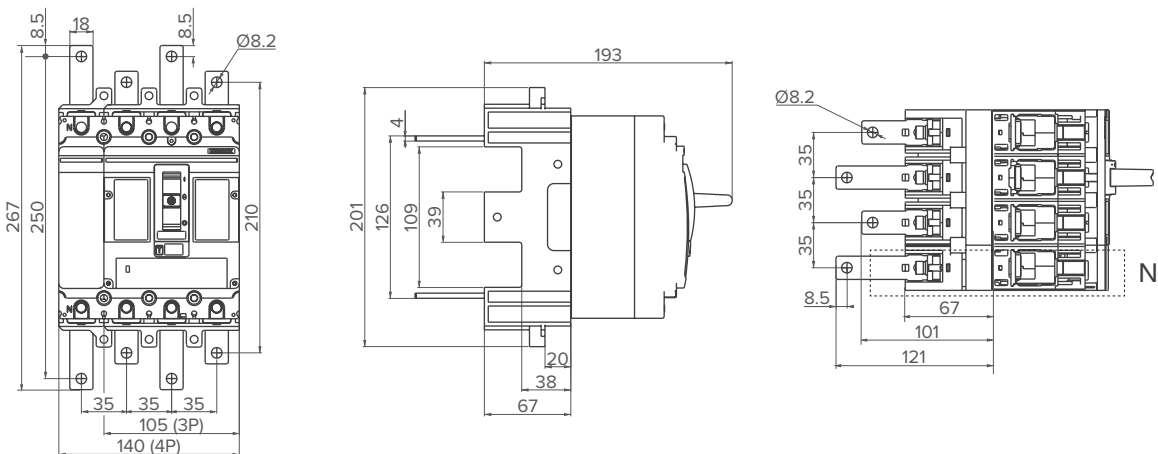

PIA 23

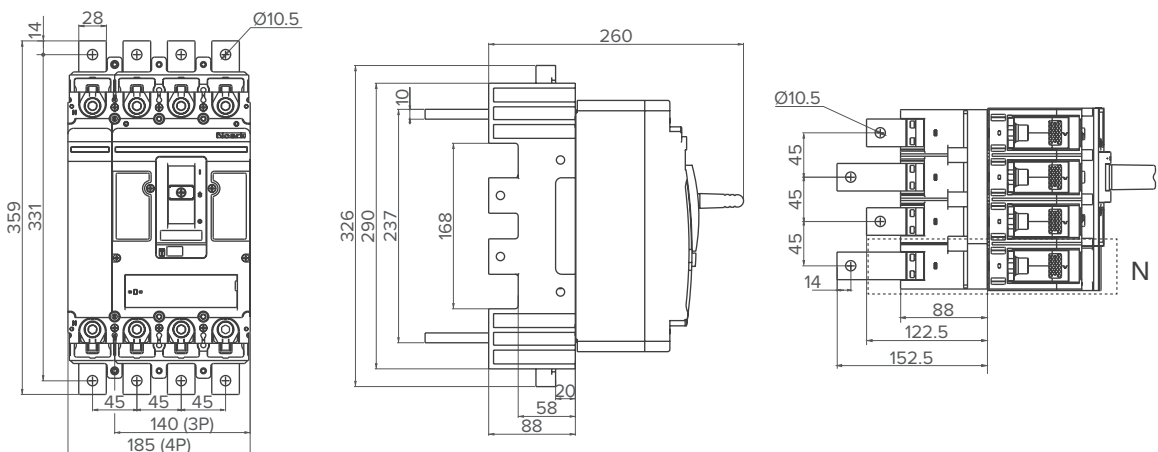

Technical Data **Ex9M** Accessories

Accessories for Moulded Case Circuit Breakers Ex9M

Draw-Out Base DOB2i

General parameters

Suitable for commercial and industrial applications
For fast service and maintenance of the installation
Suitable for circuit breakers of frame sizes from M3 til M5
TM and electronic versions of Ex9M3 have different types of bases
Premounted with automatic safety trip mechanism to avoid damages while unplug the circuit breaker.
Offered with front type and back type of terminals.
In scope of delivery the tripping mechanism, base position indicators, phase barriers, MCCB plug-in terminals, auxiliary terminals for the cassette, mounting screws, phase barriers and the draw-out base.

Derating coefficient of Tripping Characteristics on accessories combination

Nominal current	I_n (T) [A]					
	Ex9M3 TM	Ex9M4 TM	Ex9M5 TM	Ex9M3 SU20	Ex9M4 SU20	Ex9M5 SU20
250 A	1	—	—	1	—	—
315 A	1	—	—	—	—	—
350 A	1	—	—	—	—	—
400 A	1	0.95	—	1	—	—
500 A	1	0.95	—	—	—	—
630 A	—	0.95	0.95	0.9 ($\leq 570A$)	0.95	—
700 A	—	—	0.95	—	—	—
800 A	—	—	0.9	—	—	0.9

Mechanical parameters

	DOB 23	DOB 24
Device width 3P / 4P	214 mm / 259 mm	281 mm / 346 mm
Device height front / back connection	342 mm / 312 mm	485 mm / 275 mm
Device depth with MCCB mounted front connection	280 mm	270 mm
Device depth with MCCB mounted back connection	315.5 mm	332.5 mm
Mounting	onto panel / DIN rail 35mm	
Degree of protection	IP40, IP20 terminals	
Terminals	M10 screws	M12 screws
Busbar width	≤ 30 mm	≤ 40 mm
Cable lug width	≤ 30 mm	≤ 40 mm
Fastening torque of terminals	25 Nm	30 Nm
Ambient temperature	-40 — +70 °C	
Relative humidity	≤ 50 % at 40 °C, ≤ 90 % monthly average	
Weight 3P / 4P	8 / 10 kg (≤ 400 A) 8.1 / 10.12 kg (630A)	15.25 / 18.36 kg
Mounting position	vertical, can be rotated by 90° in each axis	

Technical Data **Ex9M** Accessories

Accessories for Moulded Case Circuit Breakers Ex9M

Draw-Out Base DOB2i

Dimensions

DOB 23 CO

mm

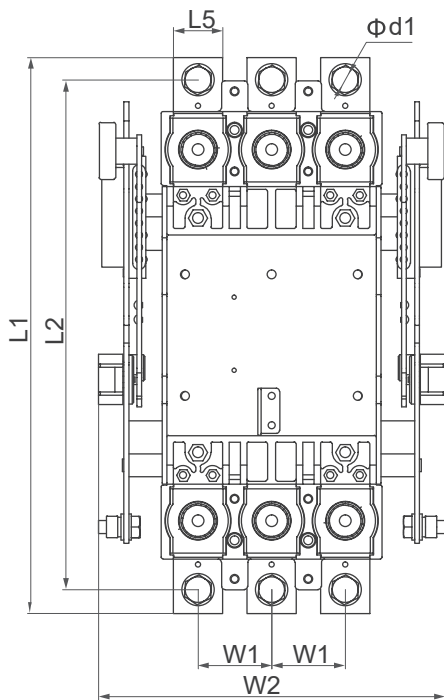
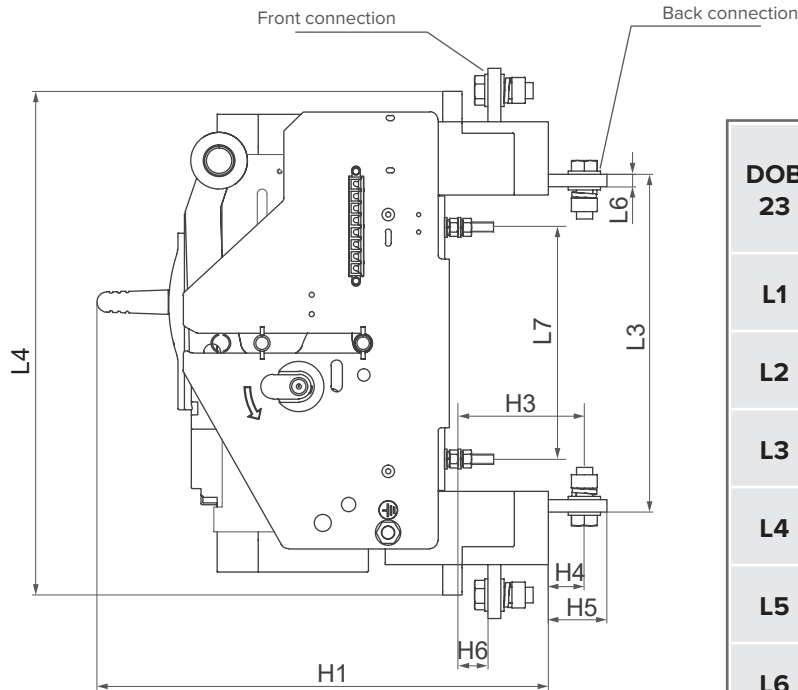

DOB 23	≤400 A		>400 A	
	3P	4P	3P	4P
L1	342	342	342.5	342.5
L2	313	313	314.5	314.5
L3	207	207	210.5	210.5
L4	312	312	313.5	313.5
L5	30	30	30	30
L6	6	6	8	8
L7	143	143	143	143
H1	280	280	280	280
H3	77	77	77.5	77.5
H4	21	21	21.5	21.5
H5	35.5	35.5	35.5	35.5
H6	17.5	17.5	17.5	17.5
W1	45	45	45	45
W2	214	259	214	259
Ø d1	11	11	11	11

Technical Data **Ex9M** Accessories

Accessories for Moulded Case Circuit Breakers Ex9M

Draw-Out Base DOB2i

Dimensions

DOB 24 CO

mm

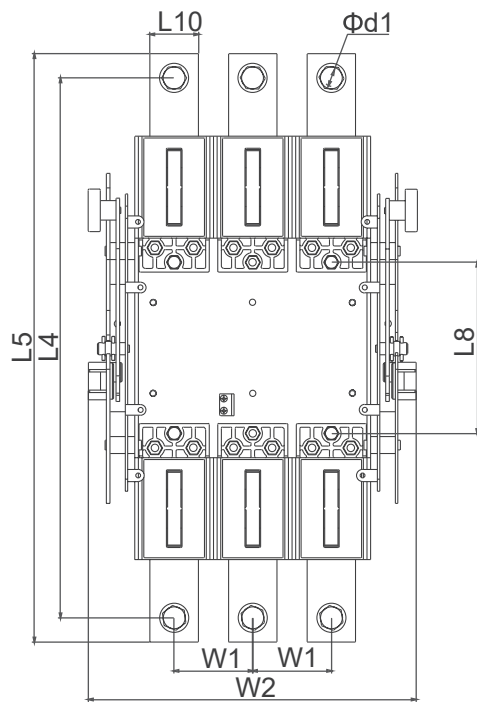
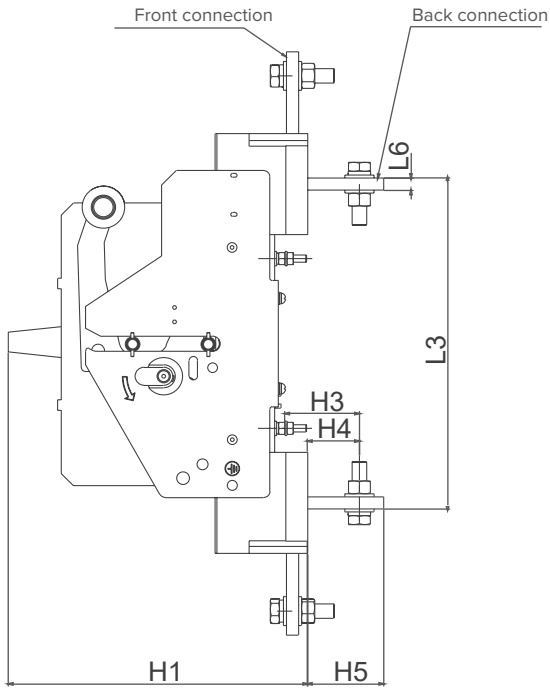

DOB 24	3P	4P
L3	275	275
L4	445	445
L5	485	485
L6	10	10
L8	141	141
L10	40	40
H1	270	270
H3	61	61
H4	42.5	42.5
H5	62.5	62.5
W1	65	65
W2	281	346
$\Phi d1$	13	13

Technical Data **Ex9M** Accessories

Accessories for Moulded Case Circuit Breakers Ex9M

DIN-rail adaptors DRA2i

General parameters

Adaptors for mounting of MCCBs and MCCB Switch Disconnectors onto 35 mm device DIN-rail

Suitable for M1 and M2 frame sizes, 3P and 4P versions

Mechanical parameters

	DRA21	DRA22
Suitable for	M1	M2
Mounting	easy mounting onto 35 mm device rail (DIN)	

Drawings and dimensions

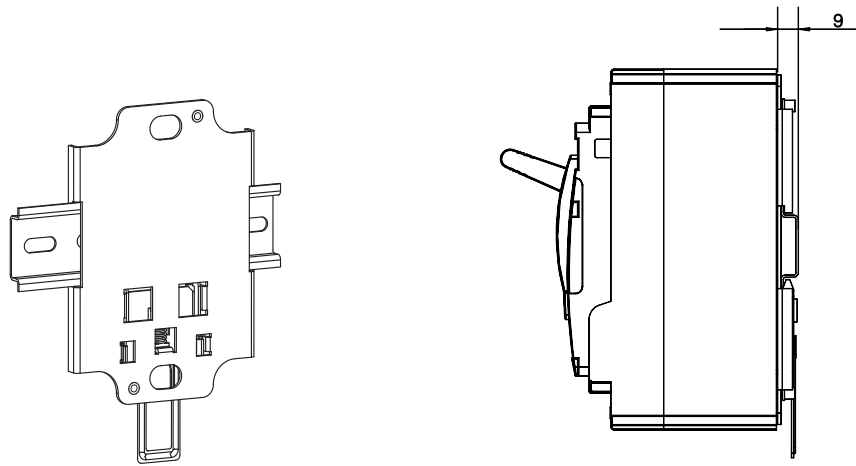

Technical Data **Ex9M** Accessories

Accessories for Moulded Case Circuit Breakers Ex9M

Mounting depth spacers WG

General parameters

Set of mounting depth spacers for compensation of differences in height between frame sizes

Suitable for all variants of MCCBs and MCCB Switch Disconnectors

Variants with height 10 and 13 mm

Mechanical parameters

	WG 10	WG 13
Suitable for height compensation	M1 -> M2	M2 -> M3 M3 -> M4/M5
Height	10 mm	13 mm

Mounting

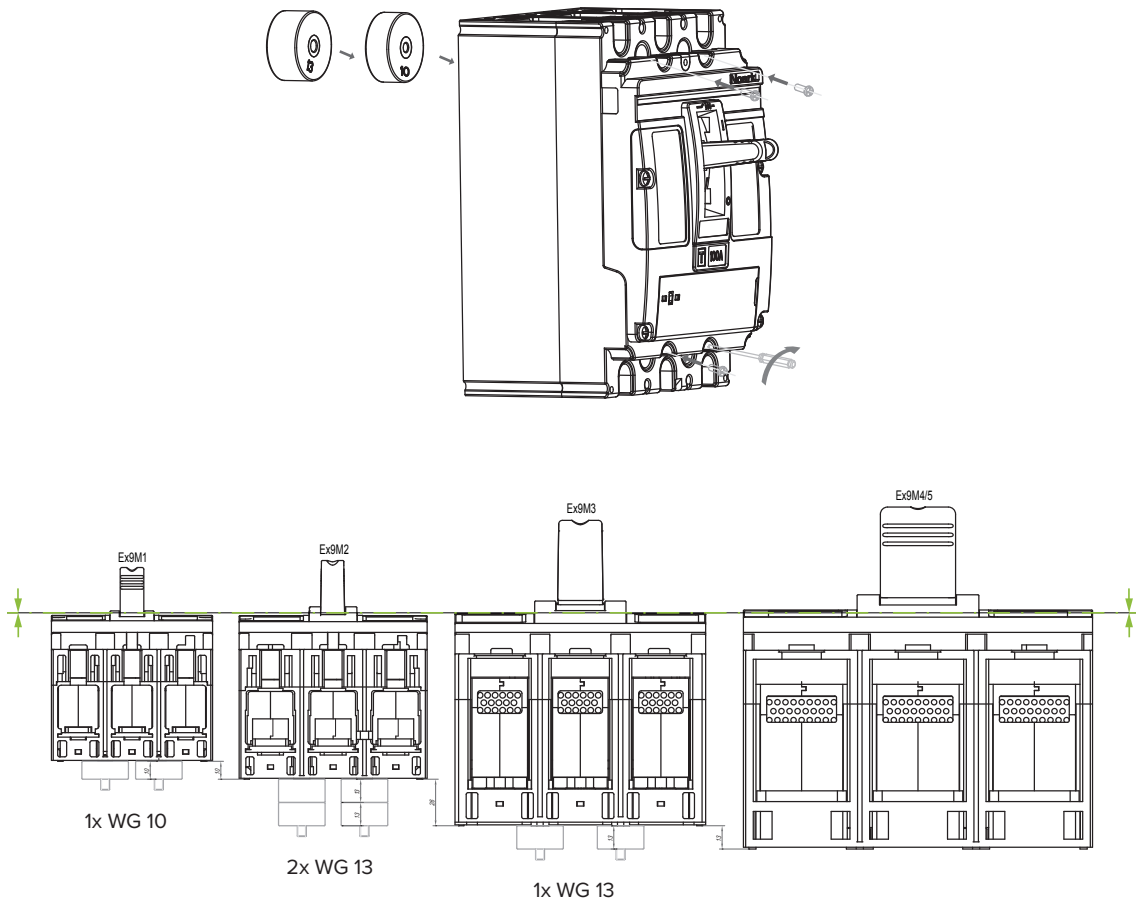

WG \ Ex9M	9M1/9M2	9M1/9M3	9M1/9M4	9M2/9M3	9M2/9M4	9M3/9M4
	WG10	4X	4X	4X		
WG13		8X	12X	8X	12X	4X

Technical Data **Ex9M** Accessories

Accessories for Moulded Case Circuit Breakers Ex9M

Battery box (BAB22)

General parameters

Battery box for external power supply of SU20S type MCCBs

Suitable for circuit breakers of frame sizes from M2 to M6

In scope of delivery 1.5 meter Mini-DIN Plug 8 pin cable

Operating conditions

Basic parameters	Performance indicators
Operating temperature	-20° C - +40° C
Operating output voltage*	DC 9V
Capacity*	120mA H

Dimensions

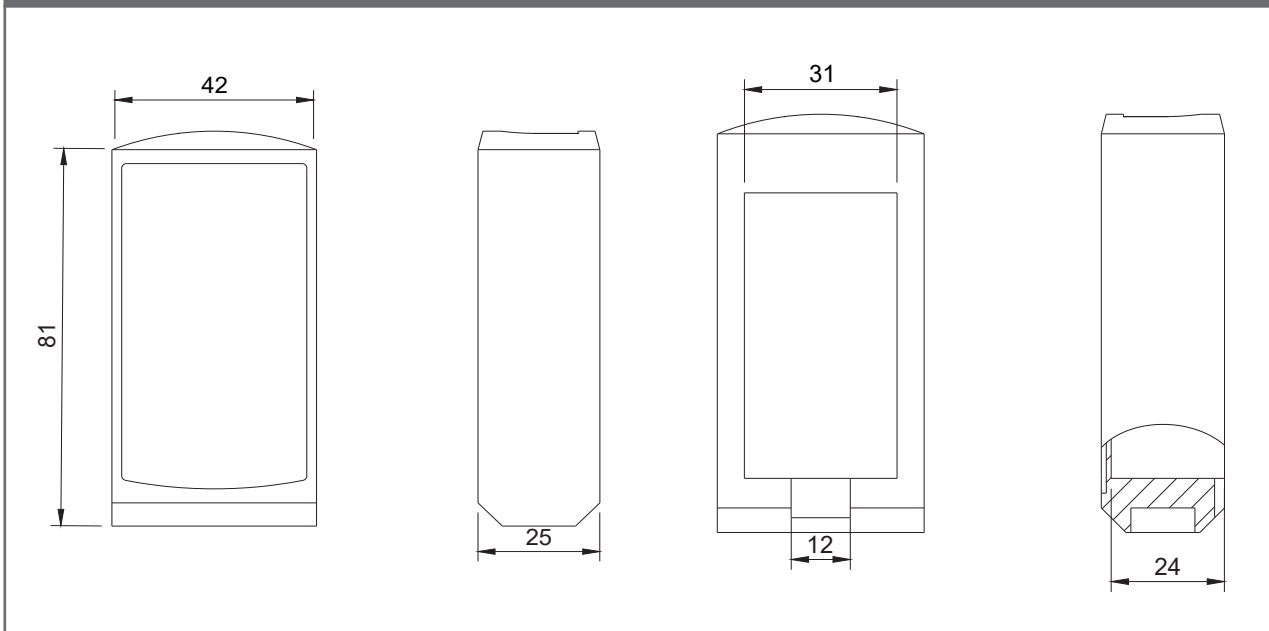

Usual battery dimensions

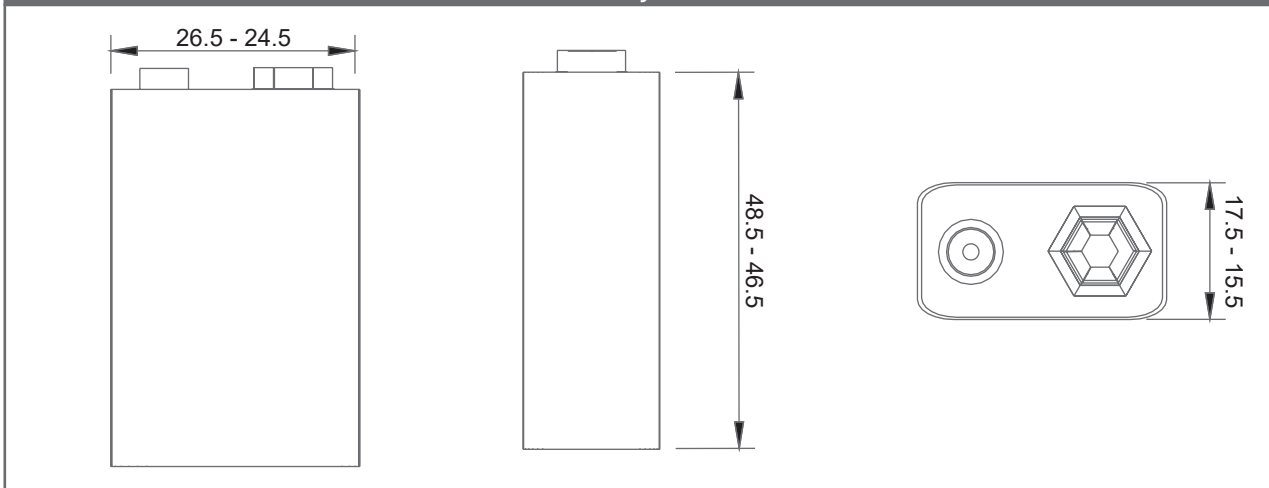

Note: * The battery is not included

Technical Data **Ex9M** Accessories

Accessories for Moulded Case Circuit Breakers Ex9M

Communication module COM22

General parameters

Auxiliary component of moulded case circuit breakers used for networking and communication of MCCBs to facilitate remote control for users.

COM22 refers to universal accessory of standard type electronic moulded case circuit breaker

Electrical parameters

Basic parameters	Performance indicators
Operating power supply	AC220V, range: AC85V - AC265V or DC24V
Communication	RS485 communication - Baud rate: 9600/19200bps
Two way relay output	Output capacity 3 A 30 V DC/250 V A

Mechanical parameters

Basic parameters	Performance indicators
Operating temperature	-25°C - 75°C
Mounting	DIN steel rail (TS35x7.5mm) same as miniature circuit breaker.

Dimensions

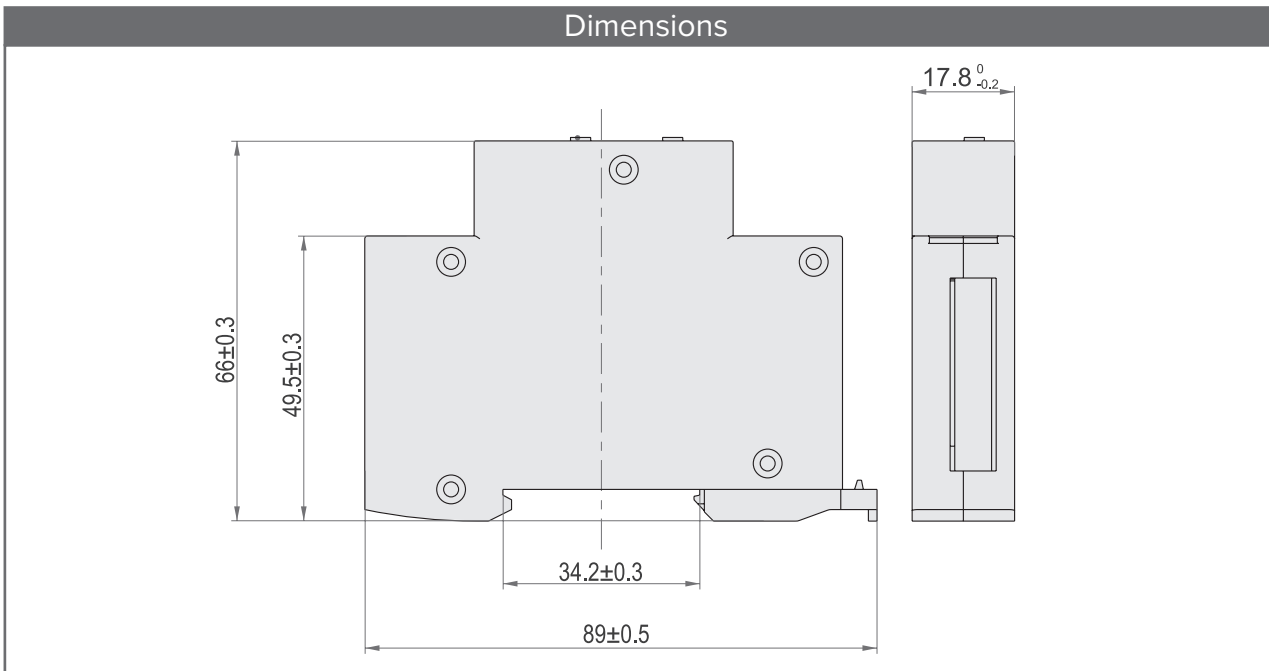

Technical Data **Ex9M** Accessories

Accessories for Moulded Case Circuit Breakers Ex9M

Communication module COM22

Wiring diagram

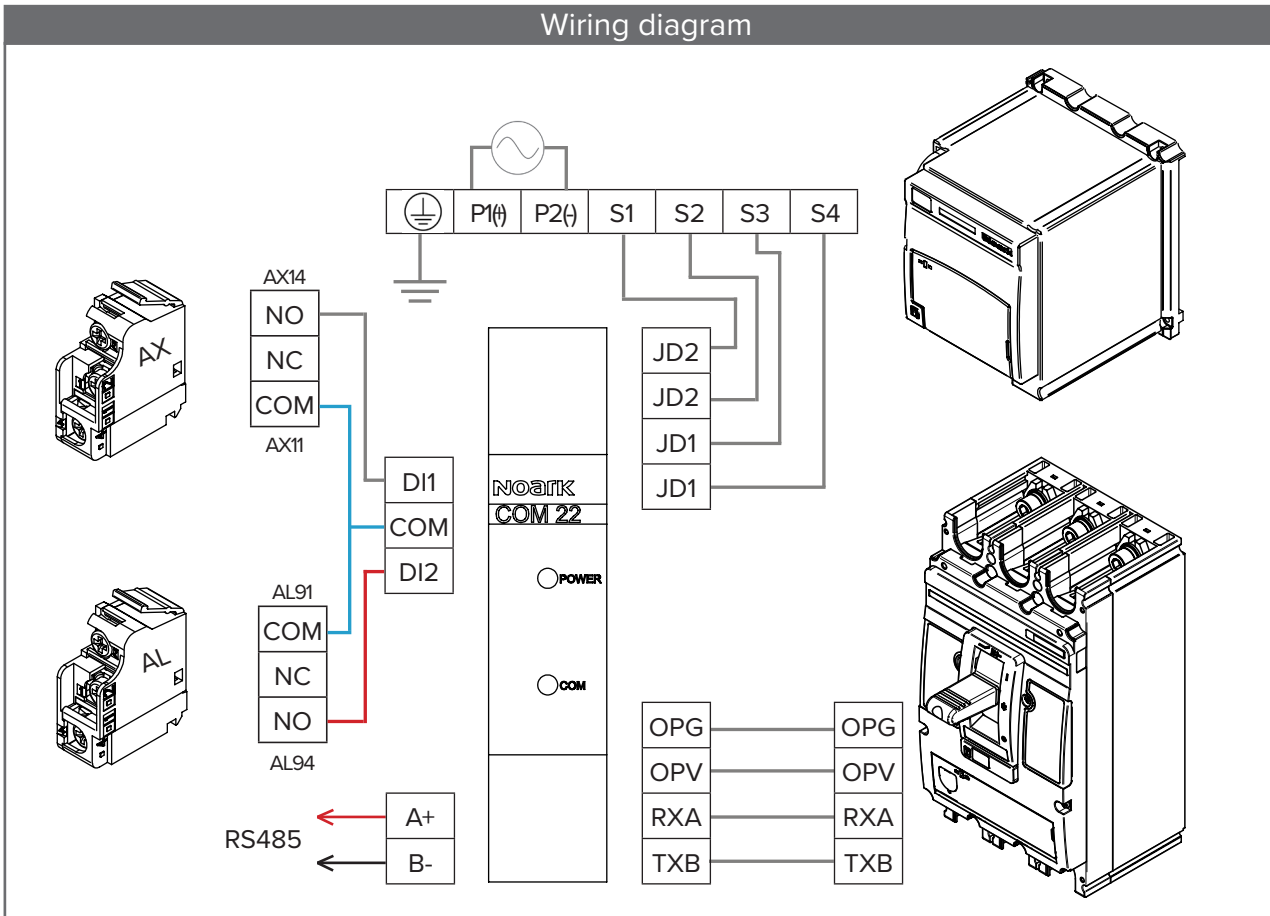

Technical Data **Ex9M** Accessories

Accessories for Moulded Case Circuit Breakers Ex9M

Communication module COM22

Function parameter settings

Breaker metering data

Item	Address	Permissions	Notes	SU20S	SU20L
L1 Phase current (A)	0x0001	R		✓	✓
L2 Phase current (A)	0x0002	R		✓	✓
L3 Phase current (A)	0x0003	R		✓	✓
N Phase current (A)	0x0004	R		✓	✓
Ground phase current (A)	0x0005	R		✓	-
1st Fault Status Words	0x003B	R	Break alarming state: 0 = Normal; 1 = Fault Bit 15: L1 phase current fault Bit 14: L2 phase current fault Bit 13: L3 phase current fault Bit 12: N phase current fault Bit 11: Instantaneous/Short circuit fault Bit 10: Short-time delay fault Bit 09: Long time / Overload fault Bit 08: Ground fault Bit 07: Phase unbalance fault (motor type) Bit 06: Motor block fault (motor type) Others: reserve, default return value 0	✓	✓
1st Fault current	0x003C	R		✓	✓
2nd Fault Status Words	0x003D	R	Same with 0x003B	✓	✓
2nd Fault current	0x003E	R		✓	✓
3rd Fault Status Words	0x003F	R	Same with 0x003B	✓	✓
3rd Fault current	0x0040	R		✓	✓

Communication setup

Item	Address	Permissions	Notes	SU20S	SU20L
Modbus address	0x0100	R/W	Range 1-247	✓	✓
Modbus baud rate	0x0101	R/W	Options: 9600, 19200	✓	✓

Device information

Item	Address	Permissions	Notes	SU20S	SU20L
Frame current (A)	0x0180	R	Options:250, 630, 800, 1600	✓	✓
Rated current (A)	0x0181	R	250A frame: 32, 63, 100, 160, 250 630A frame: 250, 400, 630 800A frame: 800, 630 1600A frame: 800, 1000, 1250, 1600	✓	✓
Software version	0x01C5 - 0x01CC	R		✓	✓

Control function

(Write permission of control command default is OFF, can be enabled with "Net Permit" in controller menu)

Item	Address	Permissions	Notes	SU20S	SU20L
Control command	0x2800	W	Bits 9:8 Breaker state: 01 = break; 10 = make Bit 4 Break test = stand by; 1= trigger Others: Reserve	✓	✓

Technical Data **Ex9M** Accessories

Accessories for Moulded Case Circuit Breakers Ex9M

Communication module COM22

Function parameter settings

Protect functions

(Write permission of protection parameters default is OFF, can be enabled with "Net Permit" in controller menu)

Item	Address	Permissions	Notes	SU20S	SU20L
Long time delay current setting (I _r)	0x2007	R/W*	0.4-1.0 I _n	✓	R/O
Long time delay time setting (T _r) (s)	0x2008	R/W*	Power distribution type: 3, 6, 12, 18 Motor type: 5, 10, 20, 230 (250A frame and below: 5,10, 20)	✓	R/O
Short time delay current setting (I _{sd})	0x2009	R/W*	Range: Power distribution type (1.5-10) I _r (OFF); Motor type (4-12) I _r (OFF)	✓	R/O
Short time time setting (T _{sd}) (s)	0x200A	R/W*	Power distribution type: 100, 200, 300, 400; Motor type: 100	✓	R/O
Short circuit Instantaneous current setting (I _i)	0x200B	R/W*	Power distribution type: (1.5-12) I _n (OFF); Motor type: 15	✓	R/O
Ground fault protection current setting (I _g)	0x200C	R/W	Options: (0.4, 0.5, 0.6 0.7, 0.8, 0.9, 1.0) I _n	✓	-
Ground fault protection time setting (T _g) (s)	0x200D	R/W	Options: 100, 200, 300, 400	✓	-
N phase protection current setting (I _N)	0x200E	R/W*	Options: 5 (0.5I _n), 10 (1.0I _n)	✓	R/O
3 phase unbalance	0x200F	R/W*	Options: (0.3, 0.4, 0.5, 0.6, 0.7, 0.8, 0.9) Only motor type	✓	R/O
3 phase unbalance time delay setting	0x2010	R/W*	Options: 4, 6, 8, 10 Only motor type	✓	R/O
Motor block current setting	0x2011	R/W	Options: (3-10) I _r (OFF) Only motor type	✓	-
Motor block delay time setting (s)	0x2012	R/W	Options: (1-30) Only motor type	✓	-
Long time protection enable	0x2013	R/W	Options: 1 (ON) or 0 (OFF) Only motor type	✓	-
Short time protection enable	0x2014	R/W	Options: 1 (ON) or 0 (OFF)	✓	-
Instantaneous protection enable	0x2015	R/W	Power distribution type: Options: 1 (ON) or 0 (OFF) Motor: 1 (ON)	✓	-
N phase protection enable	0x2016	R/W	Options: 1 (ON) or 0 (OFF)	✓	-
Ground fault protection enable	0x2017	R/W	Options: 1 (ON) or 0 (OFF)	✓	-
3 phase unbalance enable	0x2018	R/W	Options: 1 (ON) or 0 (OFF) Only motor type	✓	-
Motor block protection enable	0x2019	R/W	Options: 1 (ON) or 0 (OFF) Only motor type	✓	-
Frequency of current	0x201A	R/W	Options: 1 (50Hz) or 0 (60Hz)	✓	-

Technical Data **Ex9M** Accessories

Accessories for Moulded Case Circuit Breakers Ex9M

Compatibility table

Product family	Frame size	Manual operation	Remote operation	MOD Motor drive		SHT Shunt trip release		UVT Undervoltage release	
Ex9M	M1	✓	With external accessory	MOD21	Ordered separately	SHT21	Ordered separately	UVT21	Ordered separately
Ex9M	M2	✓	With external accessory	MOD22	Ordered separately	SHT22	Ordered separately	UVT22	Ordered separately
Ex9M	M3	✓	With external accessory	MOD23	Ordered separately	SHT22	Ordered separately	UVT22	Ordered separately
Ex9M	M4	✓	With external accessory	MOD24	Ordered separately	SHT24	Ordered separately	UVT24	Ordered separately
Ex9M	M5	✓	With external accessory	MOD24	Ordered separately	SHT24	Ordered separately	UVT24	Ordered separately
Ex9M	M6	✓	-	-	-	SHT26	Ordered separately	UVT26	Ordered separately
Ex9M6 MOD	M6	✓	With premounted internal accessory	MD26 (premounted)	Premounted accessory (not offered separately)	SHT26 (premounted)	Premounted accessory	UVT26	Ordered separately

Product family	Frame size	Manual operation	Remote operation	XF Closing release		AX Auxiliary contact		AL Signal contact	
Ex9M	M1	✓	With external accessory	-	-	AX21M	Ordered separately	AL21M	Ordered separately
Ex9M	M2	✓	With external accessory	-	-	AX21M	Ordered separately	AL21M	Ordered separately
Ex9M	M3	✓	With external accessory	-	-	AX21M	Ordered separately	AL21M	Ordered separately
Ex9M	M4	✓	With external accessory	-	-	AX21M	Ordered separately	AL21M	Ordered separately
Ex9M	M5	✓	With external accessory	-	-	AX21M	Ordered separately	AL21M	Ordered separately
Ex9M	M6	✓	-	-	-	AX21M	Ordered separately	AL21M	Ordered separately
Ex9M6 MOD	M6	✓	With premounted internal accessory	XF26 (premounted)	Premounted accessory (not offered separately)	SHT26 (premounted)	Premounted accessory	AL21M (premounted)	Premounted accessory